

NOVA PRO SCALA

Drawer H122



- The elegant intermediate height for special applications
- Can be customised using designer panels
- Integrated height, side and tilt angle adjustment
- Straight inside surfaces and narrow installation width ensure optimal utilisation of space
- Sturdy construction and high degree of stability
- Tool-free fitting and removal of the front
- Same bottom panel and back panel width
- No need to machine the bottom panel

Note:

- Front-bottom connector recommended for KB 800 mm and above (see page 350)

ORDER INFORMATION

1 Nova Pro Scala drawer sides H122 Set: one left, one right

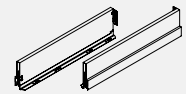

NL	Stone			Ice			Silver		
	Art. No.			Art. No.			Art. No.		
400	F100103225			F100103252			F100103279		
450	F100103228			F100103255			F100103282		
500	F100103231			F100103258			F100103285		
550	F100103234			F100103261			F100103288		
600	F100103237			F100103264			F100103291		

2 Installation hook Single item: can be used on left/right



	Description	Art. No.			
32 mm	Expansion dowel	F102117719			
50 mm	Expansion dowel	F102117720			
32 mm	For press fitting	F102021854			
50 mm	For press fitting	F102021153			
	For screw fitting	F102021855			

Nova Pro slides from page 320 onwards

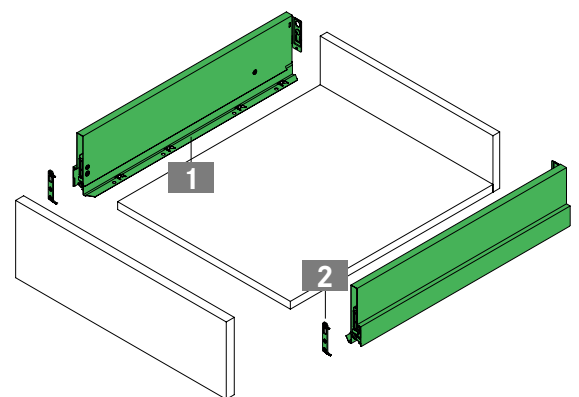
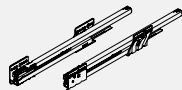

PAGE REFERENCES

Tipmatic Soft-close	324	Accessories	348	Sensomatic	617
Designer panels	338	Technical information	352	Assembly technology	637
Application examples	342	Organising systems	577	Assembly aids	658

PLANNING DIMENSIONS

All dimensions in millimetres

Front panel installation dimensions	Back panel installation dimensions	Cutting dimensions for 16 mm chipboard												
<table border="1"> <thead> <tr> <th colspan="3">Slide</th> </tr> </thead> <tbody> <tr> <td>S</td> <td>16/19</td> <td>18</td> </tr> <tr> <td>EB</td> <td>29</td> <td>30</td> </tr> <tr> <td>A</td> <td>21.5</td> <td>22.5</td> </tr> </tbody> </table> <p>Note: Slide available in two versions: S16/S19 and S18. See the chapter on slides (from page 320 onwards).</p>			Slide			S	16/19	18	EB	29	30	A	21.5	22.5
Slide														
S	16/19	18												
EB	29	30												
A	21.5	22.5												
<p>* Recommendation/minimum dimension: 49.5 mm/Tipmatic Soft-close: 58 mm</p>														

Mounting positions for full extension slide

Euro screw Ø 6 x 13 mm

40 kg **70 kg**

LEGEND

B	Bottom panel	FST	Front overlay	NL	Nominal length
BB/BL	Bottom panel width/length	KV	Cabinet front edge	RW	Back panel
EB	Installation width	LWK	Inside cabinet width	RWB	Back panel width
FAS	Front overlay, side	MET	Minimum installation depth	RWH	Back panel height

