

# NOVA PRO SCALA

## Drawer H90

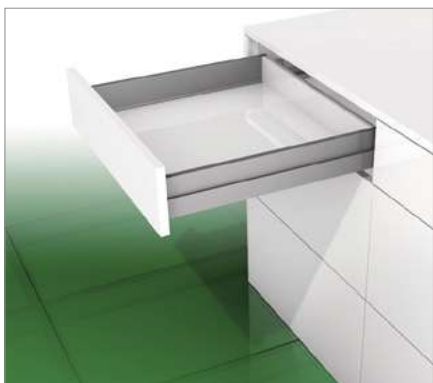

- The practical standard drawer for every application
- Can be customised using designer panels
- Integrated height and side adjustment
- Straight inside surfaces and narrow installation width ensure optimal utilisation of space
- Sturdy construction and high degree of stability
- Tool-free fitting and removal of the front
- Same bottom panel and back panel width
- No need to machine the bottom panel

### Note:

- Front-bottom connector recommended for KB 800 mm and above (see page 350)

## ORDER INFORMATION

1 Nova Pro Scala drawer sides H90 Set: one left, one right												
NL	Stone				Ice				Silver			
	Art. No.				Art. No.				Art. No.			
270	F100103108				F100103135				F100103162			
300	F100103111				F100103138				F100103165			
350	F100103114				F100103141				F100103168			
400	F100103117				F100103144				F100103171			
450	F100103120				F100103147				F100103174			
500	F100103123				F100103150				F100103177			
550	F100103126				F100103153				F100103180			
600	F100103129				F100103156				F100103183			
650	F100103132				F100103159				F100103186			

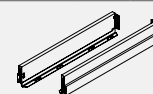

2 Installation hook Single item: can be used on left/right			
	Description	Art. No.	
32 mm	Expansion dowel	F102117719	
50 mm	Expansion dowel	F102117720	
32 mm	For press fitting	F102021854	
50 mm	For press fitting	F102021153	
	For screw fitting	F102021855	

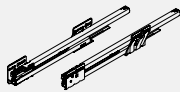

Nova Pro slides from page 320 onwards	
	

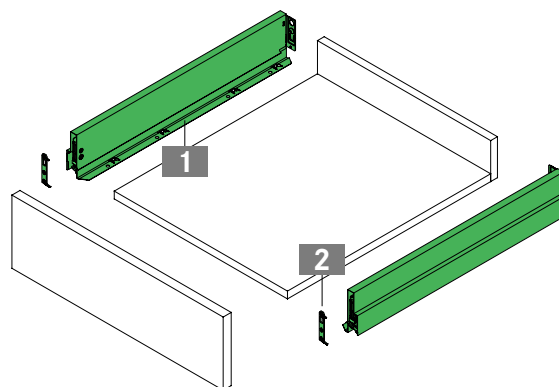

## PAGE REFERENCES

Tipmatic Soft-close	324	Designer panels	338	Technical information	352
Inset panels	328	Application examples	342	Organising systems	577
Oval railing	336	Accessories	348	Sensomatic	617

**PLANNING DIMENSIONS**

All dimensions in millimetres

Front panel installation dimensions	Back panel installation dimensions	Cutting dimensions for 16 mm chipboard												
<table border="1"> <thead> <tr> <th>Slide</th> <th>S</th> <th>16/19</th> <th>18</th> </tr> </thead> <tbody> <tr> <td>EB</td> <td>29</td> <td>30</td> <td></td> </tr> <tr> <td>A</td> <td>21.5</td> <td>22.5</td> <td></td> </tr> </tbody> </table> <p><b>Note:</b> Slide available in two versions: S16/S19 and S18. See the chapter on slides (from page 320 onwards).</p>			Slide	S	16/19	18	EB	29	30		A	21.5	22.5	
Slide	S	16/19	18											
EB	29	30												
A	21.5	22.5												
<p>* Recommendation/minimum dimension: 49.5 mm/Tipmatic Soft-close: 58 mm</p>														

Mounting positions for full extension slide

**40 kg**      **70 kg**

**LEGEND**

<b>B</b>	Bottom panel	<b>FST</b>	Front overlay	<b>NL</b>	Nominal length
<b>BB/BL</b>	Bottom panel width/length	<b>KV</b>	Cabinet front edge	<b>RW</b>	Back panel
<b>EB</b>	Installation width	<b>LWK</b>	Inside cabinet width	<b>RWB</b>	Back panel width
<b>FAS</b>	Front overlay, side	<b>MET</b>	Minimum installation depth	<b>RWH</b>	Back panel height

