

Cam fitting Rastex 15



- With torque support – allows furniture sides to be pulled into place from distances up to 4 mm from the panel end
- Twice as secure thanks to internal and external indentations – the dowel is always pulled in to the centred position, ruling out any displacement of furniture components.
- Cam can be tightened with a slot screwdriver or crosshead screwdriver PZ 3 or Allen key SW 4
- Useable in 16, 18, or 22 mm panels
- Die-cast zinc self colour

Finish	Product code	PU
For 16 mm panels	9 007 997	2000
For 18 mm panels	9 056 599	2000
For 22 mm panels	1 007 794	2000

Cover caps for Rastex 15

- Plastic



Finish	Product code	PU
white	0 071 054	200
brown	0 071 055	200
black	0 079 490	200

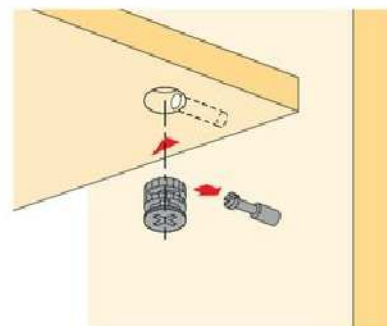

Dowels / sockets – see pages 8.2.4 – 8.2.8

Rastex 15
for 16 mm panels

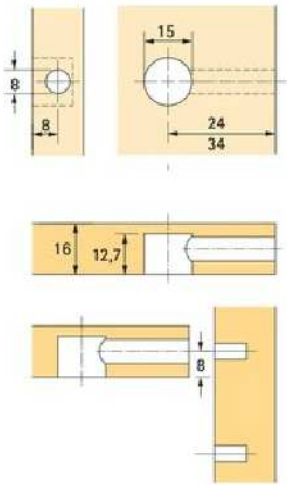

Rastex 15
for 18 mm panels

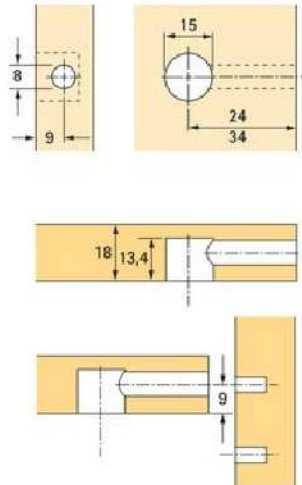

Rastex 15
for 22 mm panels

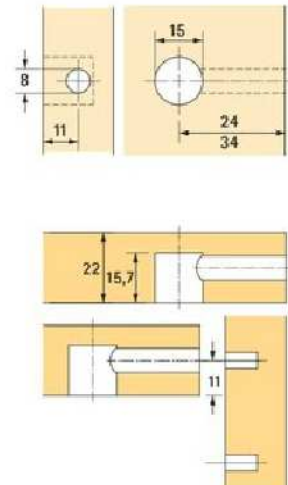

Drill bits, tungsten carbide tipped

- Turning clockwise
- Length 57 mm
- Shaft diameter 10 mm
- Diameter 15 mm

Product code	PU
9 106 107	1

Fast - faster - Rapid S

The new generation of Hettich fast assembly dowels with a steel core. Slimline, lightweight and incredibly strong. Fitted without the need for tools – the dowel simply pushes into place. With Rastex, the Rapid S makes the perfect pair.

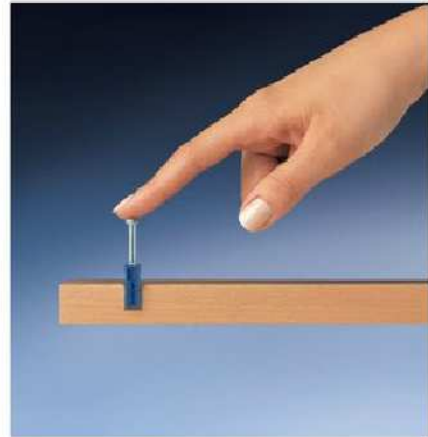

New:
extremely sturdy steel core

Colour coding for 8 mm holes

Edge ensures correct position in carcass side

Four expanding jaws for optimum expansion

Thread prevents damage to the drill hole when unscrewing the dowel



- Fast, toolless installation, simply presses by hand into the hole in the carcass side
- Reduced costs from shorter assembly times
- The stable connection closes every gap and even accepts a tolerance in the eccentric drill hole of up to 1 mm without losing pull-out strength.
- Easy to tell apart with coloured expanding elements for 8 mm (blue) drill holes
- For 8 mm \varnothing side panel drill holes with a dowel length of 20 mm or 30 mm

1. Rapid S simply pushes into the drill hole with the press of a finger. The plastic dowel shank is non-slip – making it easy to press in.

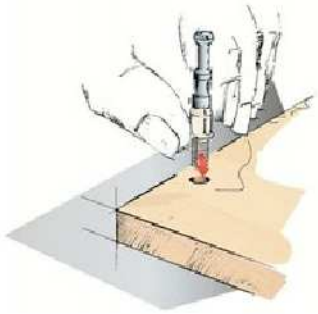

2. Rastex 15 is pushed into the mounting hole.

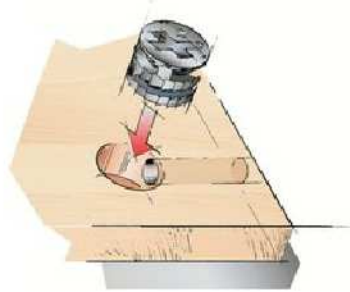

3. On tightening the Rastex 15, the socket immediately expands, significantly increasing pull-out strength. Bottom and side are joined together securely and reliably.

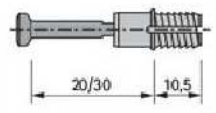
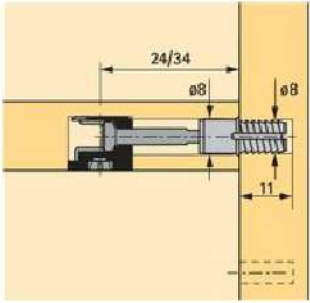
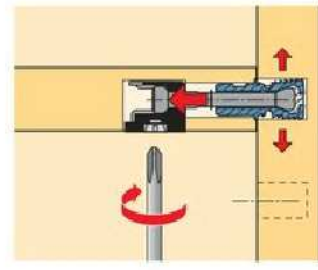
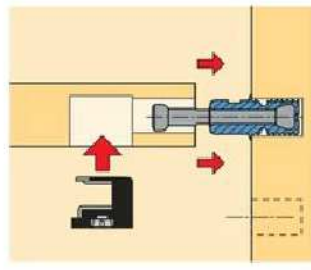
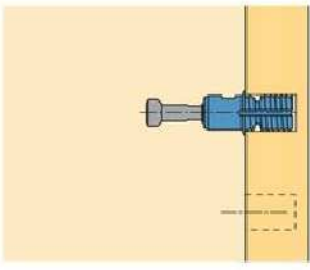
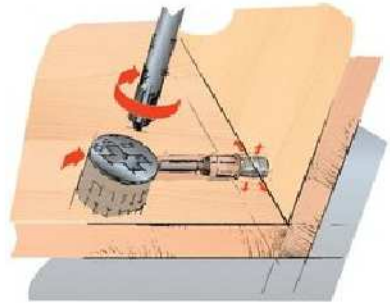

Rapid S
Fast assembly dowel DU 324/DU 325

- Expanding socket for 8 mm hole diameter
- Dowel length 20 mm/30 mm
- Steel/blue plastic



Article	Dowel length mm	Product code	PU
Rapid S DU 324	20	9 046 180	2000
Rapid S DU 325	30	9 046 182	2000



Twister – quickly fitted without the risk of injury

By holding the freely rotating sleeve, the Twister can be driven in all the way safely and reliably throughout the insertion process with the cordless screwdriver – preventing risk of injury from sharp edges or burrs.

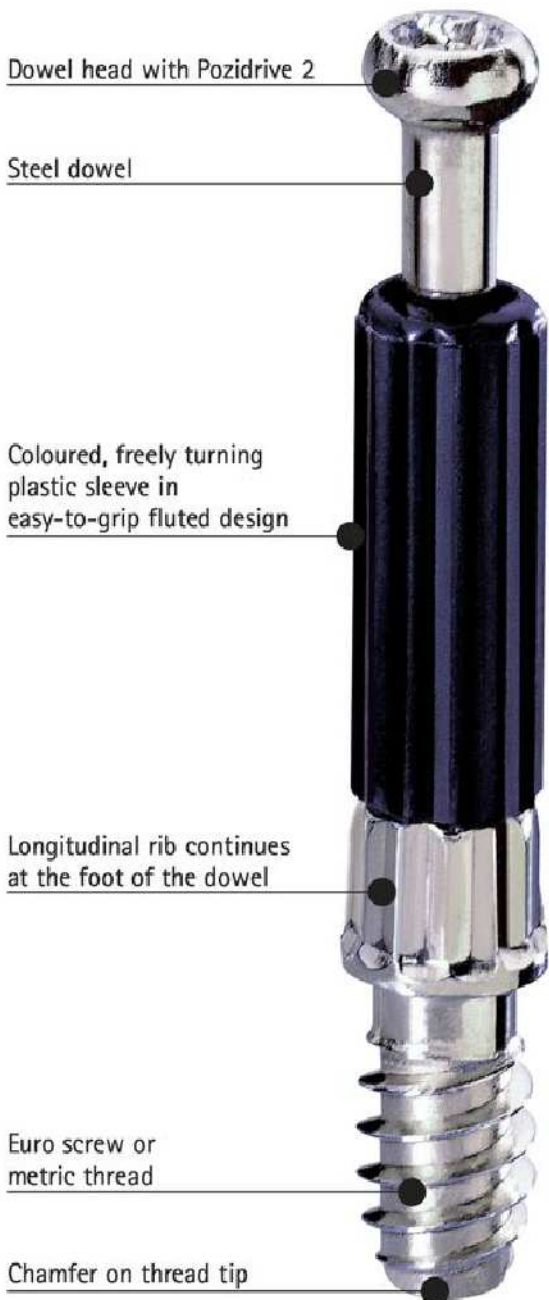

The right dowel is always at hand

- Coloured plastic sleeves in easy-to-grip fluted design indicate dowel lengths
Green → 20 mm for Rastex 15
Black → 30 mm for Rastex 15



- Direct fixing thread for System 32 hole lines with a drilling diameter of 5 mm
- M6 x 7,8 mm metric thread for plastic or brass sockets
- Excellent torque transmission from drill bit to dowel head
- Chamfer at start of thread for easy insertion into drill hole

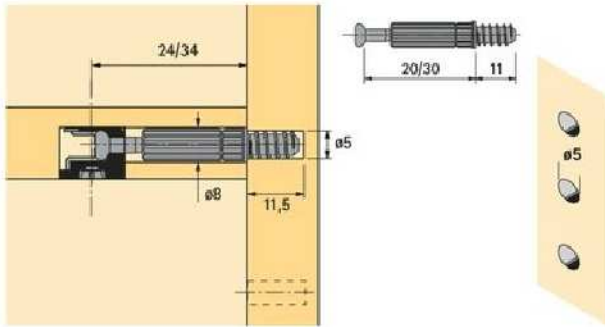

Twister Screw-in dowel DU 243/DU 232

- Euro screw thread for 5 mm hole diameter
- Dowel length 20 mm/30 mm
- Zinc-plated steel/green or black plastic

System
32



Article	Dowel length mm	Product code	PU
Twister DU 243	20	9 047 863	2000
Twister DU 232	30	9 047 861	2000

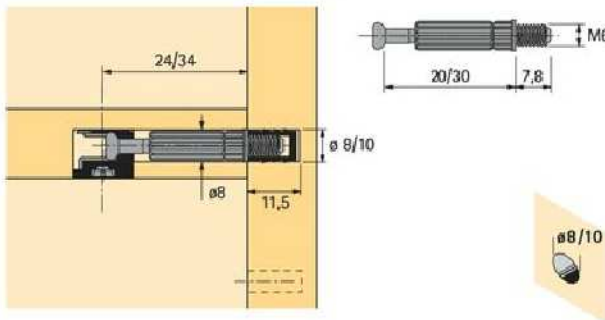

Twister Screw-in dowel DU 645/DU 644

- Thread M6 x 7,8 mm
- Dowel length 20 mm/30 mm
- Zinc-plated steel/green or black plastic



Article	Dowel length mm	Product code	PU
Twister DU 645	20	0 020 155	200
Twister DU 644	30	0 020 157	200

DU 645/DU 644 can be used with...

Expanding socket with/without nylon ball

- For thread M6
- Hole diameter 8 mm
- brass self-colour



Product code	PU
1 028 024	2000

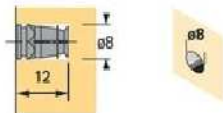

Socket no. 33

- For thread M6
- Hole diameter 10 mm
- White plastic



Product code	PU
0 079 539	200

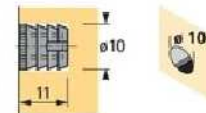

Angle dowel DU 885/DU 860

- 90° - 180° adjustable
- Hole diameter 7 mm
- Dowel length 20/20 mm or 39/39 mm
- Chromated steel

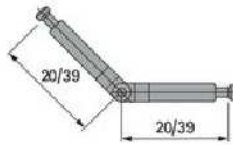
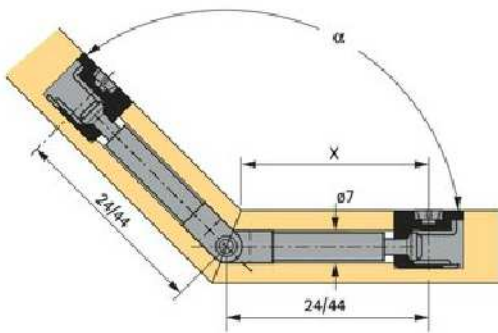

Article	Dowel length mm	Product code	PU
DU 885	20/20	1 080 252	500
DU 860	39/39	1 079 600	500

Drilling distance X for angle dowels DU 860.

Angle α	Panel thickness	
	16	22
Drilling distance X mm for DU 860		
100°	37,3	34,8
105°	37,9	35,6
110°	38,4	36,3
115°	38,9	37,0
120°	39,4	37,7
125°	39,8	38,3
130°	40,3	38,9
135°	40,7	39,4
140°	41,1	40,0
145°	41,5	40,5
150°	41,9	41,1
155°	42,2	41,6
160°	42,6	42,1

For angle dowels DU 885, drilling distance X is calculated: $X = \text{above values in table} - 20$